

Float switch

For the process industry

Model FLS (models with Ex approval: 60, AL-ADF)

KSR data sheet LM 30.01



for further approvals
see page 3

Applications

- Level measurement for almost all liquid media
- Pump and level control and monitoring of distinct filling levels
- Chemical, petrochemical industry, natural gas, offshore, shipbuilding, machine building, power generating equipment, power plants
- Process water and drinking water treatment, food and beverage industry

Special features

- Large range of application due to the simple, proven functional principle
- For harsh operating conditions, long service life
- Operating limits:
 - Operating temperature: $T = -196 \dots +350 \text{ °C}$
 - Operating pressure: $P = \text{Vacuum up to } 40 \text{ bar}$
 - Limit density: $\rho \geq 300 \text{ kg/m}^3$
- Wide variety of different electrical connections, process connections and materials
- Explosion-protected versions

Description

A float with a permanent magnet moves reliably along with the liquid level on a guide tube. Within the guide tube is fitted a reed contact (inert gas contact), which is energised, through the non-magnetic walls of the float and guide tube, by the approach of the float magnet. By using a magnet and reed contact the switching operation is non-contact, free from wear and needs no power supply. The contacts are potential-free. Float switches are also available with multiple switch points.



Fig. left: Stainless steel version, mounting thread, model FLS-S
Fig. right: Plastic version, flange connection, model FLS-P

The switching functions always refer to a rising liquid level: Normally open, normally closed or change-over contact.

Through the use of a float for a max. of 2 switch points a bistable switch behaviour can be achieved, meaning that the switching status also remains available, when the filling level continues to rise above or drop below the switch point.

The float switch is simple to mount and maintenance-free, so the costs of mounting, commissioning and operation are low.

Further special features

- Process connection, guide tube and float from stainless steel 1.4571, plastic or Buna
- Universal signal processing:
Connection direct to a PLC is possible, NAMUR connection, signal amplification / contact protection relays
- Works independently of foaming, conductivity, dielectricity, pressure, vacuum, temperature, vapours, condensation, bubble formation, boiling effects and vibrations
- Multiple functionality in a single instrument - up to 8 potential-free contacts
- Exact repeatability of the switch points
- Float switches qualify as simple apparatus in accordance with EN 60079-11 section 5.7 and can be installed in "zone 1" hazardous areas without certification, so long as the equipment is operated in a certified intrinsically safe circuit with a minimum explosion protection of Ex ib.

Options

- Customer-specific solutions
- Special versions for interface layer detection
 $\Delta\rho \geq 100 \text{ kg/m}^3$
- Process connection, guide tube and float from stainless steel 1.4435, 1.4539, titanium, Hastelloy (others on request)

Model overview









Model	Description	Materials								
		Stainless steel							Titanium 3.7035 (grade 2)	PVC / PP / PVDF
		1.4571 (316Ti)	1.4404 (316L)	1.4435 (316L)	1.4571 (316Ti) / PP	1.4571 (316Ti) / PA	1.4571 (316Ti) / Ms	1.4571 (316Ti) / Buna		
FLS-SE	Standard version, cable connection, safety extra-low voltage	x	x	x	x	x	x	x	x	
FLS-SF	Standard version, cable connection, low voltage	x	x	x	x	x	x	x	x	
FLS-SA	Standard version, connection housing or connector, low voltage	x	x	x	x	x	x	x	x	
FLS-SB	Standard version, connection housing or connector, safety extra-low voltage	x	x	x	x	x	x	x	x	
FLS-SBI (60)	Intrinsically safe, Ex i	x		x						
FLS-SAD FLS-SBD (AL-ADF)	Flameproof enclosure, Ex d	x		x						
FLS-ME	Miniature design, cable connection, safety extra-low voltage	x	x		x			x		
FLS-MB	Miniature design, connection housing or connector, safety extra-low voltage	x	x		x			x		
FLS-PF	Plastic version, cable connection, low voltage									x
FLS-PA	Plastic version, connection housing or connector, low voltage									x
FLS-HE	Pharmaceutical version, cable connection, safety extra-low voltage		x	x						
FLS-HA	Pharmaceutical version, connection housing, low voltage		x	x						
FLS-HA3	Sterile version (3-A), connection housing, low voltage		x	x						

Temperature range (process)



- Models FLS-SE, FLS-SF, FLS-HE -30 ... +150 °C
- Models FLS-SA, FLS-SB -196 ... +350 °C
- Models FLS-Sxl (60) -50 ... +180 °C
- Models FLS-SxD (AL-ADF) -10 ... +120 °C
- Models FLS-M -30 ... +150 °C
- Models FLS-P -10 ... +100 °C
- Models FLS-HA, FLS-HA3 -40 ... +200 °C

Approvals

■ Model FLS-S

Logo	Description	Country
	EU declaration of conformity <ul style="list-style-type: none"> ■ Low voltage directive ■ RoHS directive ■ ATEX directive (option) Hazardous areas - Ex i Zone 0 II 1/2G Ex ia IIC T3 ... T6 Ga/Gb No. KEMA 01 ATEX1053 X Zone 21 II 2D Ex ib IIIC T80 °C Db - Ex d Zone 1 II 2G Ex d IIC T6 Gb No. TÜV 13 ATEX 7399 X Zone 21 II 2D Ex tb IIIC T80 °C Db	European Union
		
	IECEx (option) Hazardous areas - Ex d Zone 1 Ex d IIC T6 No. IECEx TUR 09.0002X Ex tD A21 IP65 T80 °C	International
	EAC <ul style="list-style-type: none"> ■ EMC directive and low voltage directive No. RU Д-DE.A301.B.00815 ■ Hazardous areas No. RU C-DE.ГБ08.B.01489 	Eurasian Economic Community
-	PESO Hazardous areas No. A/P/HQ/MH/104/3293 / P331149	India
	DNV GL <ul style="list-style-type: none"> ■ Ships, shipbuilding (e.g. offshore) ■ Hazardous areas No. TAA00000KZ 	International
	ABS <ul style="list-style-type: none"> ■ Ships, shipbuilding (e.g. offshore) No. 16-HG1591058-PDA ■ Hazardous areas No. 16-HG1591042-PDA / KEMA 01 ATEX 1053 X 	International
	Bureau Veritas Ships, shipbuilding No. 04264/H0 und 04568/G0	International
	Lloyd's Register Ships, shipbuilding (e.g. offshore) No. 07/20006 (E2)	International
-	DIBt Safety (e.g. electr. safety, overpressure, ...) Overflow control per German Water Resources Act (WHG) § 19 No. Z-65.11-482	Germany

■ Model FLS-H

Logo	Description	Country
	EU declaration of conformity <ul style="list-style-type: none"> ■ Low voltage directive ■ RoHS directive 	European Union
	EAC EMC directive and low voltage directive No. RU Д-DE.A301.B.00815	Eurasian Economic Community
	3-A (only model FLS-HA3) Sanitary Standard No. 1698	USA

■ Model FLS-P

Logo	Description	Country
	EU declaration of conformity <ul style="list-style-type: none"> ■ Low voltage directive ■ RoHS directive 	European Union
	EAC EMC directive and low voltage directive No. RU Д-DE.A301.B.00815	Eurasian Economic Community

Approvals and certificates, see website

Application examples

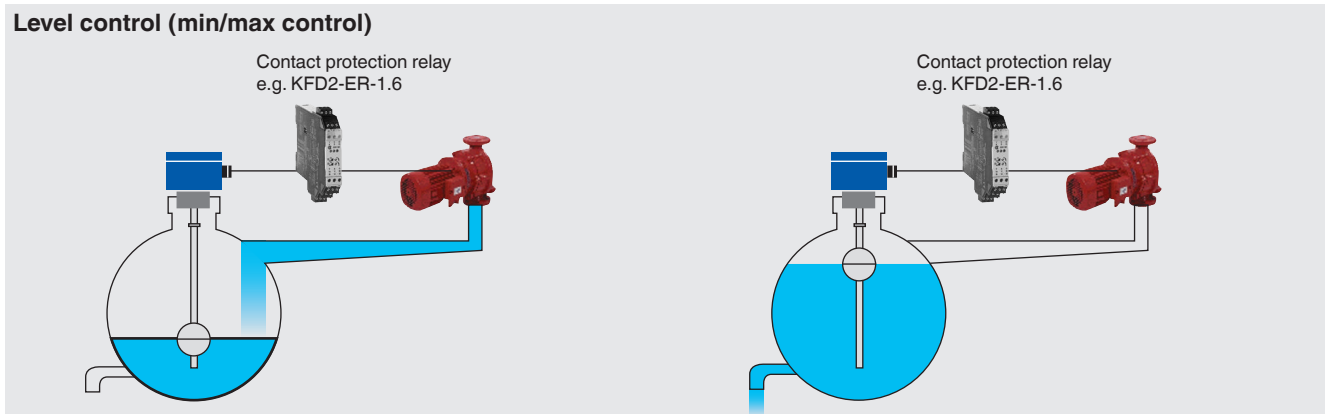
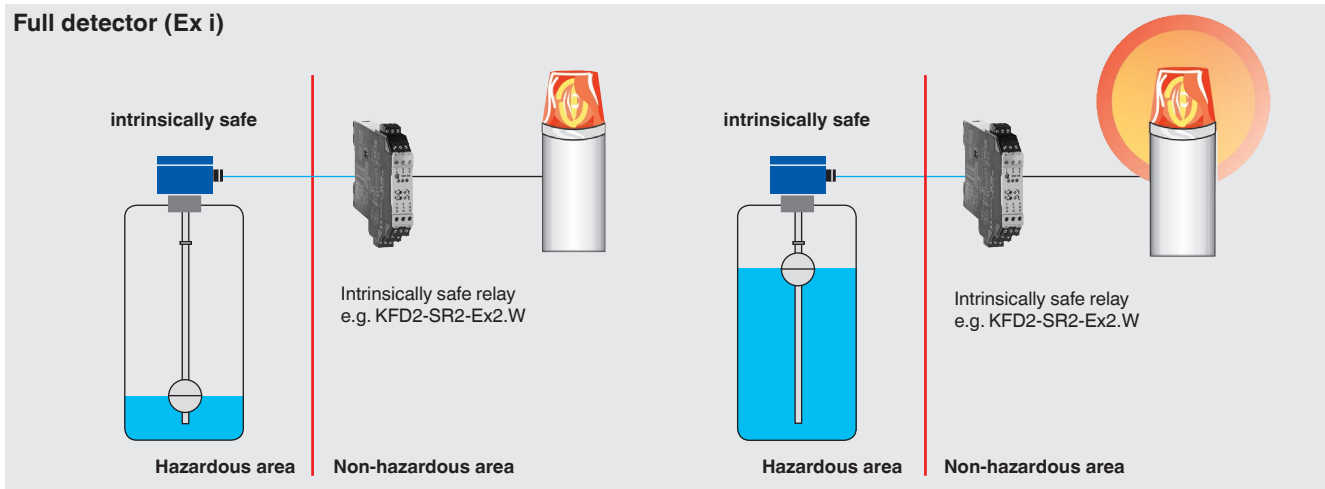

Float switch, standard version with connection housing or connector

Models FLS-SA, FLS-SB

Process connection, guide tube and float from stainless steel 1.4571 (316Ti)

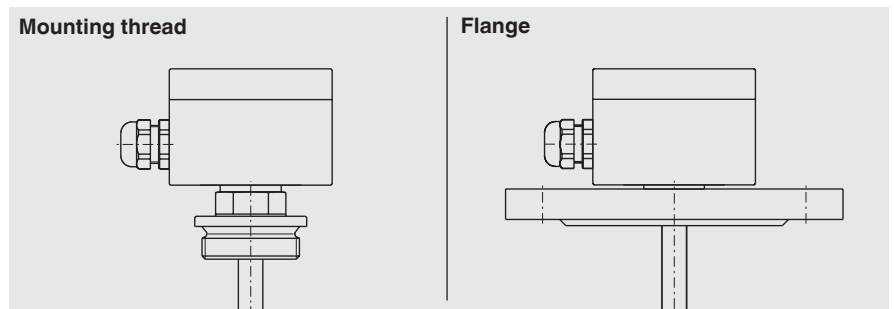
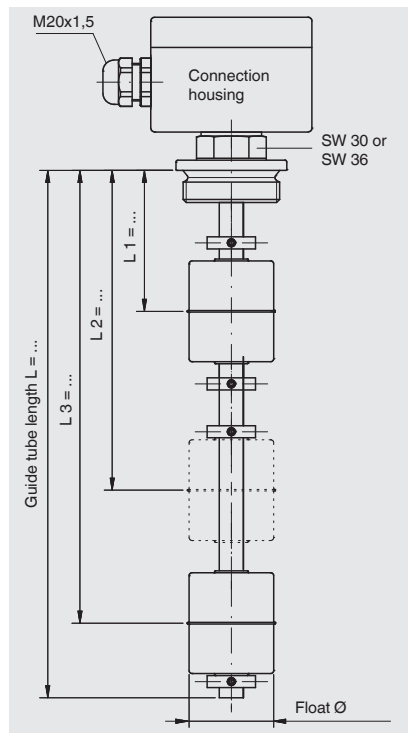

	Model FLS-SA, low voltage	Model FLS-SB, safety extra-low voltage						
Electrical connection	<ul style="list-style-type: none"> ■ Connection housing Aluminium 64 x 58 x 34 mm, with 1 contact Aluminium 80 x 75 x 57 mm, 2 or more contacts ■ Coupler connector Option: Polypropylene, polyester, stainless steel 							
Process connection	<ul style="list-style-type: none"> ■ Mounting thread downwards G 1 1/2" or G 2" ■ Mounting flange - DIN DN 50 ... DN 200, PN 6 ... PN 100 - DIN EN 1092-1 DN 50 ... DN 200, PN 6 ... PN 100 - ANSI 2" ... 8", Class 150 ... 600 others on request 							
Guide tube diameter	12 mm / 14 mm / 18 mm							
Guide tube length L	≤ 3,000 mm for guide tube diameter 12 or 14 mm ≤ 6,000 mm for guide tube diameter 18 mm							
Float	Material: Stainless steel 1.4571 (option: Buna (NBR), titanium) Float diameter: 44 ... 120 mm Float selection depending on guide tube diameter and process conditions (see page 17, 18, 19)							
Temperature range	<ul style="list-style-type: none"> ■ Standard version -30 ... +150 °C ■ High-temperature version +150 ... +350 °C ■ Low-temperature version -196 ... -30 °C Observe the temperature range of the float and the connection housing							
Switching function	Alternatively normally open (NO), normally closed (NC) or change-over (SPDT) contact - on rising level							
Max. number of contacts	6 x NO or NC, or 4 x SPDT							
Switch position	Dimensions L1, L2, L3 ... (from sealing face, starting from top)							
Distance between switch points	Minimum 20 mm (depending on the selection of the float and the contacts)							
Switching power	<table border="0"> <tr> <td> <ul style="list-style-type: none"> ■ Normally open, normally closed </td> <td> AC ≤ 230 V; 100 VA; 1 A DC ≤ 230 V; 50 W; 0.5 A </td> <td> AC < 50 V; 100 VA; 1 A DC < 75 V; 50 W; 0.5 A </td> </tr> <tr> <td> <ul style="list-style-type: none"> ■ Change-over </td> <td> AC ≤ 230 V; 40 VA; 1 A DC ≤ 230 V; 20 W; 0.5 A </td> <td> AC < 50 V; 40 VA; 1 A DC < 75 V; 20 W; 0.5 A </td> </tr> </table>		<ul style="list-style-type: none"> ■ Normally open, normally closed 	AC ≤ 230 V; 100 VA; 1 A DC ≤ 230 V; 50 W; 0.5 A	AC < 50 V; 100 VA; 1 A DC < 75 V; 50 W; 0.5 A	<ul style="list-style-type: none"> ■ Change-over 	AC ≤ 230 V; 40 VA; 1 A DC ≤ 230 V; 20 W; 0.5 A	AC < 50 V; 40 VA; 1 A DC < 75 V; 20 W; 0.5 A
<ul style="list-style-type: none"> ■ Normally open, normally closed 	AC ≤ 230 V; 100 VA; 1 A DC ≤ 230 V; 50 W; 0.5 A	AC < 50 V; 100 VA; 1 A DC < 75 V; 50 W; 0.5 A						
<ul style="list-style-type: none"> ■ Change-over 	AC ≤ 230 V; 40 VA; 1 A DC ≤ 230 V; 20 W; 0.5 A	AC < 50 V; 40 VA; 1 A DC < 75 V; 20 W; 0.5 A						
Mounting position	Vertical ±30°							
Ingress protection	up to IP66 or IP68 per IEC/EN 60529 (depending on version)							

Float switch, standard version with cable connection Models FLS-SE, FLS-SF

Process connection, guide tube and float from stainless steel 1.4571 (316Ti)

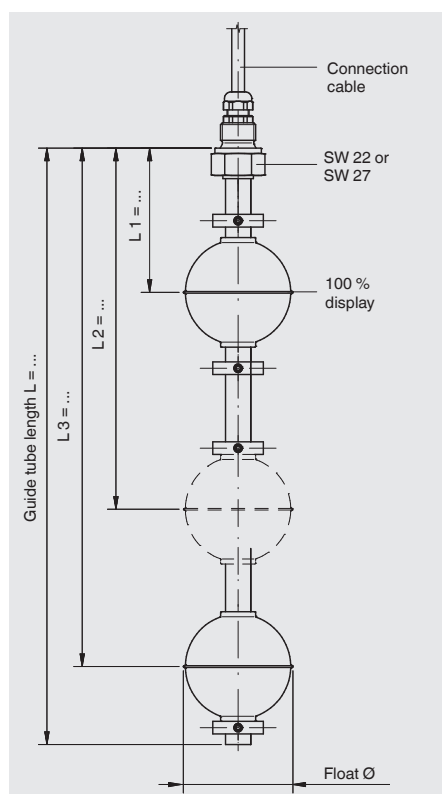

	Model FLS-SF, low voltage	Model FLS-SE, safety extra-low voltage
Electrical connection	Connection cable ■ PVC ■ Silicone ■ PUR	
Process connection	Mounting thread upwards: G 3/8" or G 1/2" others on request	
Guide tube diameter	12 mm / 14 mm / 18 mm	
Guide tube length L	≤ 3,000 mm for guide tube diameter 12 or 14 mm ≤ 6,000 mm for guide tube diameter 18 mm	
Float	Material: Stainless steel 1.4571 (option: Buna (NBR), titanium) Float diameter: 44 ... 120 mm Float selection depending on guide tube diameter and process conditions (see page 17, 18, 19)	
Temperature range	PVC/PUR cable -10 ... +80 °C Silicone cable -30 ... +150 °C Observe the temperature range of the float	
Switching function	Alternatively normally open (NO), normally closed (NC) or change-over (SPDT) contact - on rising level	
Max. number of contacts	6 x NO or NC, or 4 x SPDT for PVC and PUR cable 5 x NO or NC, or 3 x SPDT for silicone cable	
Switch position	Dimensions L1, L2, L3 ... (from sealing face, starting from top)	
Distance between switch points	Minimum 20 mm (depending on the selection of the float and the contacts)	
Switching power		
■ Normally open, normally closed	AC ≤ 230 V; 100 VA; 1 A DC ≤ 230 V; 50 W; 0.5 A	AC < 50 V; 100 VA; 1 A DC < 75 V; 50 W; 0.5 A
■ Change-over	AC ≤ 230 V; 40 VA; 1 A DC ≤ 230 V; 20 W; 0.5 A	AC < 50 V; 40 VA; 1 A DC < 75 V; 20 W; 0.5 A
Mounting position	Vertical ±30°	
Ingress protection	up to IP66 or IP68 per IEC/EN 60529 (depending on version)	

Float switch, explosion-protected version Ex i, intrinsically safe Model FLS-SBI (60)

KEMA 01 ATEX 1053 X (II 1/2G Ex ia IIC T3 ... T6 Ga/Gb or II 2D Ex ib IIIC T80 °C Db)

Process connection, guide tube and float from stainless steel 1.4571 (316Ti)

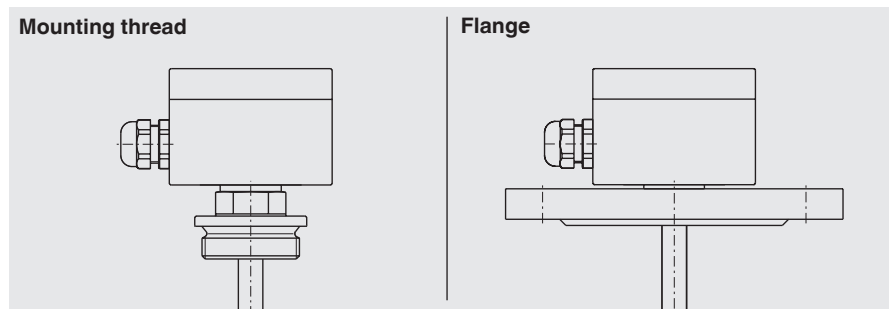
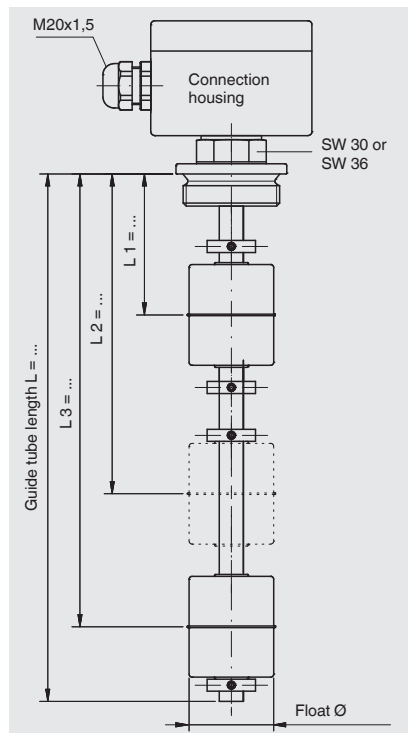

Model FLS-SBI	
Electrical connection	Connection housing: Aluminium Option: Polyester, stainless steel
Process connection	<ul style="list-style-type: none"> ■ Mounting thread downwards G 1 1/2" or G 2" ■ Mounting flange <ul style="list-style-type: none"> - DIN DN 50 ... DN 200, PN 6 ... PN 100 - DIN EN 1092 DN 50 ... DN 200, PN 6 ... PN 100 - ANSI 2" ... 8", Class 150 ... 600 others on request
Guide tube diameter	12 mm / 14 mm / 18 mm
Guide tube length L	≤ 3,000 mm for guide tube diameter 12 or 14 mm ≤ 6,000 mm for guide tube diameter 18 mm
Float	Material: Stainless steel 1.4571 (option: Buna (NBR), titanium) Float diameter: 44 ... 120 mm Float selection depending on guide tube diameter and process conditions (see page 17, 18, 19)
Temperature class	T3 T4 T5 T6
■ Process temperature	≤ 180 °C ≤ 130 °C ≤ 95 °C ≤ 80 °C
■ Ambient temperature	≤ 60 °C ≤ 60 °C ≤ 60 °C ≤ 60 °C
Switching function	Alternatively normally open (NO), normally closed (NC) or change-over (SPDT) contact - on rising level
Max. number of contacts	6 x NO or NC, or 4 x SPDT for guide tube diameter 12, 14 or 18 mm
Switch position	Dimensions L1, L2, L3 ... (from sealing face, starting from top)
Distance between switch points	Minimum 20 mm (depending on the selection of the float and the contacts)
Switching power	Only for connection to a certified intrinsically safe circuit with max. U _i = 36 V I _i = 100 mA C _i = 0 nF L _i = 0 μH
Mounting position	Vertical ±30°
Ingress protection	up to IP66 or IP68 per IEC/EN 60529 (depending on version)

Float switch, explosion-protected version Ex d, flameproof enclosure

Models FLS-SAD, FLS-SBD (AL-ADF)

TÜV 13 ATEX 7399 X (II 2G Ex d IIC T6 Gb or II 2 D Ex tb IIIC T80 °C Db)

Process connection, guide tube and float from stainless steel 1.4571

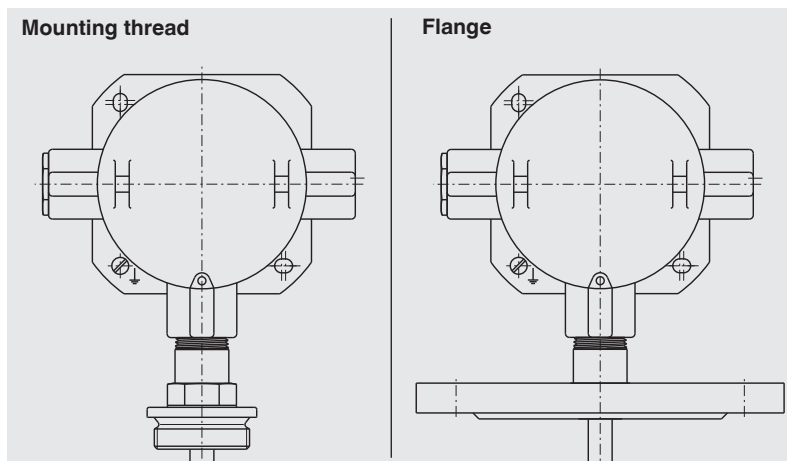
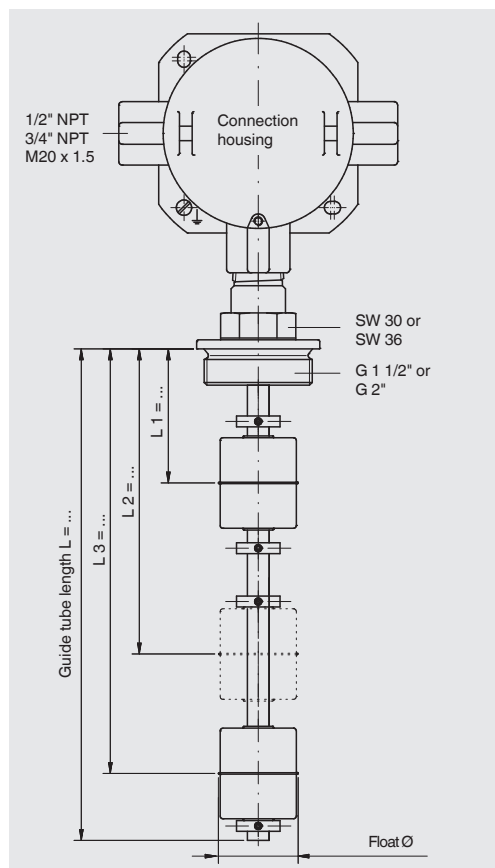

	Model FLS-SAD	Model FLS-SBD
Electrical connection	Connection housing: Aluminium Option: Stainless steel	
Process connection	<ul style="list-style-type: none"> ■ Mounting thread downwards G 1 1/2" or G 2" ■ Mounting flange - DIN DN 50 ... DN 350, PN 6 ... PN 40 - ANSI 2" ... 14", Class 150 ... 300 others on request 	
Guide tube diameter	12 mm / 14 mm	
Guide tube length L	≤ 4,000 mm for guide tube diameter 12 mm ≤ 6,000 mm for guide tube diameter 14 mm	
Float	Material: Stainless steel 1.4571 Float diameter: 44 ... 80 mm Float selection depending on guide tube diameter and process conditions (see page 17, 18, 19)	
Temperature range ■ Process temperature	T4 ≤ 120 °C	T5 ≤ 95 °C
		T6 ≤ 80 °C
Switching function	Change-over SPDT - on rising level	
Max. number of contacts	4 x SPDT	
Switch position	Dimensions L1, L2, L3 ... (from sealing face, starting from top)	
Distance between switch points	Minimum 20 mm (depending on the selection of the float and the contacts)	
Switching power	AC ≤ 230 V; 100 VA; 1.5 A DC ≤ 230 V; 60 W; 1.5 A	<ul style="list-style-type: none"> ■ With series resistance AC < 50 V; 40 VA; 150 mA DC < 75 V; 20 W; 150 mA ■ With NAMUR circuit per DIN EN 60947-5-6 AC < 50 V; 40 VA; 7 mA DC < 75 V; 20 W; 7 mA
Mounting position	Vertical ±30°	
Ingress protection	up to IP66 or IP68 per IEC/EN 60529 (depending on version)	

Float switch, miniature design

Models FLS-ME, FLS-MB

Process connection, guide tube 8 mm and float from stainless steel 1.4571 (316Ti)

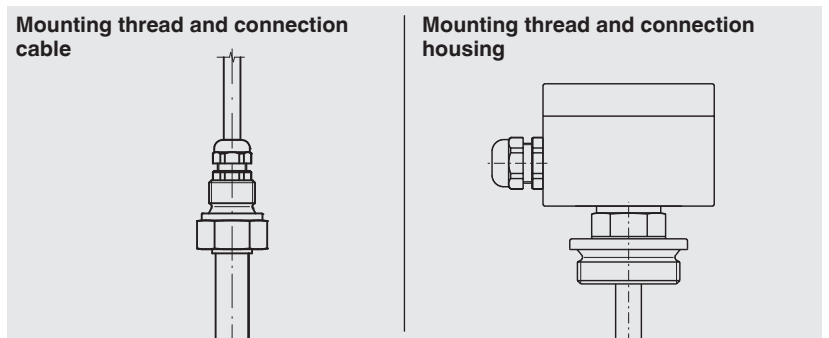
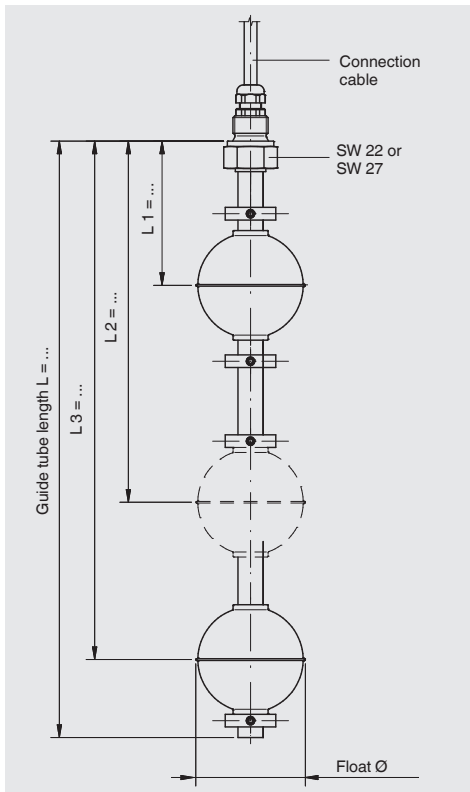

	Model FLS-ME	Model FLS-MB
Electrical connection	Connection cable ■ PVC ■ Silicone ■ PUR	■ Connection housing: Aluminium 64 x 58 x 34 mm ■ Coupler connector
Process connection	Mounting thread upwards G 1/8" others on request	Mounting thread downwards G 3/4" or G 1" others on request
Guide tube diameter	8 mm	
Guide tube length L	≤ 500 mm	
Float	Material: Stainless steel 1.4571 (option: Buna (NBR), titanium, PP) Float diameter from 20 ... 35 mm Float selection depending on guide tube diameter and process conditions (see page 17, 18, 19)	
Temperature range	PVC/PUR cable -10 ... +80 °C Silicone cable -30 ... +150 °C Observe the permissible temperature range of the float.	Buna (NBR), PP -10 ... +80 °C Stainless steel, titanium -30 ... +150 °C Observe the permissible temperature range of the float.
Switching function	Alternatively normally open (NO), normally closed (NC) or change-over (SPDT) contact - on rising level	
Max. number of contacts	3 x NO or NC, or 1 x SPDT	
Switch position	Dimensions L1, L2, L3 ... (from sealing face, starting from top)	
Distance between switch points	Minimum 20 mm (depending on the selection of the float and the contacts)	
Switching power	■ Normally open, normally closed AC < 50 V; 10 VA; 0.5 A DC < 75 V; 5 W; 0.25 A ■ Change-over AC < 50 V; 5 VA; 0.25 A DC < 75 V; 2.5 W; 0.15 A	
Mounting position	Vertical ±30°	
Ingress protection	up to IP66 or IP68 per IEC/EN 60529 (depending on version)	

Float switch, miniature design

Models FLS-MA, FLS-MF

Process connection, guide tube 8 mm and float from stainless steel 1.4571 (316Ti)

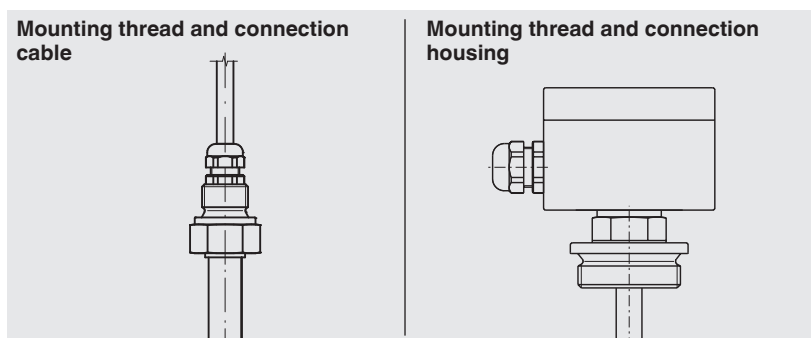
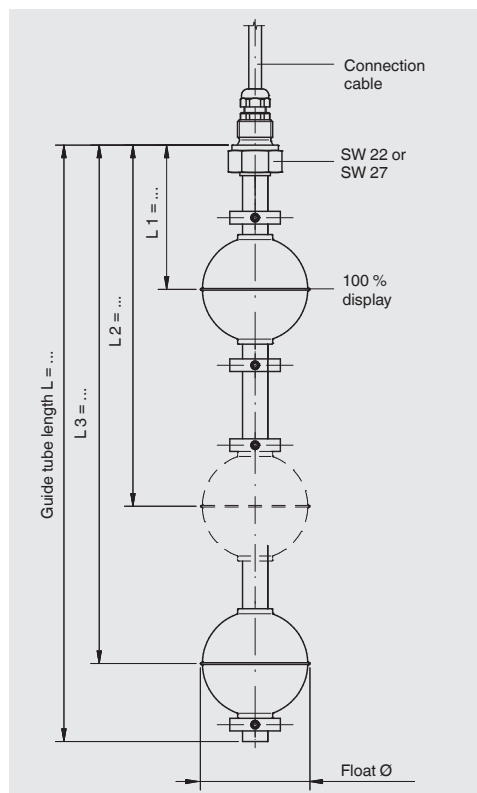

	Model FLS-MA	Model FLS-MF
Electrical connection	Connection cable ■ PVC ■ Silicone ■ PUR	■ Connection housing: Aluminium 64 x 58 x 34 mm ■ Coupler connector
Process connection	Mounting thread upwards G 1/8" others on request	Mounting thread downwards G 3/4" or G 1" others on request
Guide tube diameter	8 mm	
Guide tube length L	≤ 500 mm	
Float	Material: Stainless steel 1.4571 (option: Buna (NBR), titanium, PP) Float diameter from 20 ... 35 mm Float selection depending on guide tube diameter and process conditions (see page 17, 18, 19)	
Temperature range	PVC/PUR cable -10 ... +80 °C Silicone cable -30 ... +150 °C Observe the permissible temperature range of the float.	Buna (NBR), PP -10 ... +80 °C Stainless steel, titanium -30 ... +150 °C Observe the permissible temperature range of the float.
Switching function	Alternatively normally open (NO) or normally closed (NC) - on rising level	
Max. number of contacts	3 x NO or NC	
Switch position	Dimensions L1, L2, L3 ... (from sealing face, starting from top)	
Distance between switch points	Minimum 20 mm (depending on the selection of the float and the contacts)	
Switching power Normally open, normally closed	AC ≤ 230 V; 10 VA; 0.5 A DC ≤ 230 V; 5 W; 0.25 A	
Mounting position	Vertical ±30°	
Ingress protection	up to IP66 or IP68 per IEC/EN 60529 (depending on version)	

Float switch, plastic version

Models FLS-PA, FLS-PF

Process connection, guide tube and float from PVC, PP or PVDF

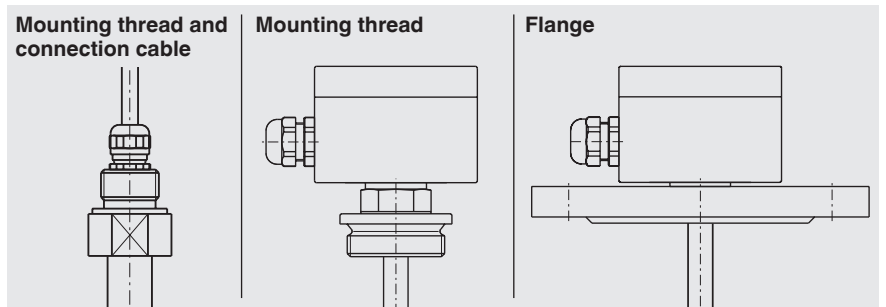
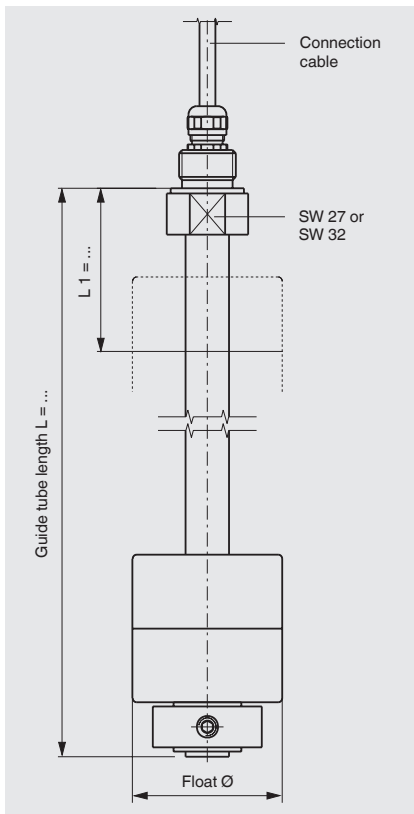

	Model FLS-PF	Model FLS-PA
Electrical connection	Connection cable ■ PVC ■ PUR	■ Connection housing polypropylene 80 x 82 x 55 mm ■ Connection housing polyester 80 x 75 x 55 mm ■ Coupler connector
Process connection	Mounting thread upwards G 3/8" others on request	Mounting thread downwards G 1 1/2" or G 2" Flange ■ DIN DN 50 ... DN 200, PN 6 ... PN 100 ■ DIN EN 1092-1 DN 50 ... DN 200, PN 6 ... PN 100 ■ ANSI 2" ... 8", Class 150 ... 600
Guide tube diameter	12 mm / 16 mm / 20 mm	
Guide tube length L	≤ 500 mm for guide tube diameter 12 mm ≤ 3,000 mm for guide tube diameter 16 mm ≤ 5,000 mm for guide tube diameter 20 mm	
Float	Material: PVC, PP or PVDF Float diameter from 44 ... 80 mm Float selection depending on guide tube diameter and process conditions (see page 17, 18, 19)	
Temperature range	For float material PVC 0 ... 60 °C For float material PP -10 ... +80 °C For float material PVDF -10 ... +100 °C	
Switching function	Alternatively normally open (NO), normally closed (NC) or change-over (SPDT) contact - on rising level	
Max. number of contacts	6 x NO or NC, or 4 x SPDT	
Switch position	Dimensions L1, L2, L3 ... (from sealing face, starting from top)	
Distance between switch points	Minimum 20 mm (depending on the selection of the float and the contacts)	
Switching power	■ Normally open, normally closed AC ≤ 230 V; 100 VA; 1 A DC ≤ 230 V; 50 W; 0.5 A ■ Change-over AC ≤ 230 V; 40 VA; 1 A DC ≤ 230 V; 20 W; 0.5 A	
Mounting position	Vertical ±30°	
Ingress protection	up to IP66 or IP68 per IEC/EN 60529 (depending on version)	

Float switch, pharmaceutical version

Models FLS-HA, FLS-HE

Process connection, guide tube and float from stainless steel

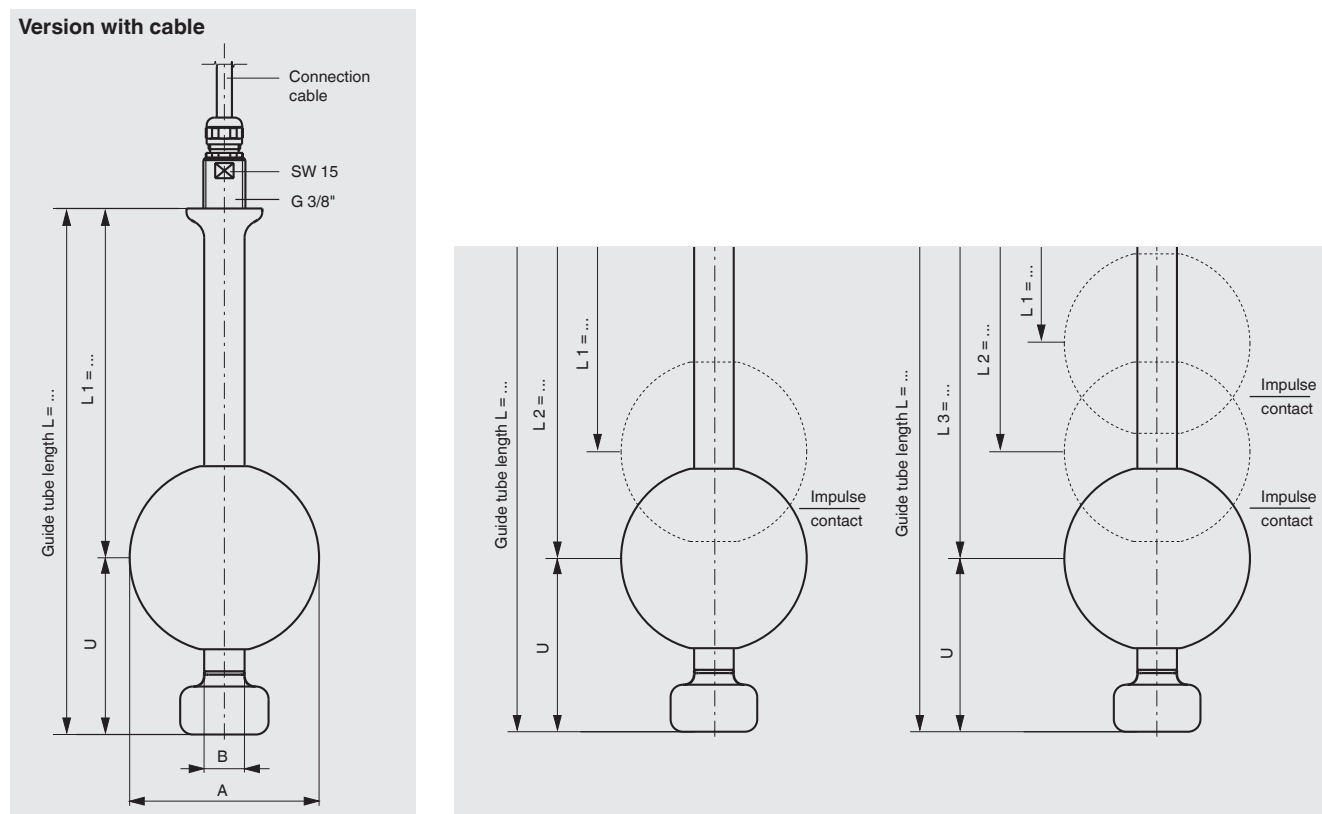

	Model FLS-HA	Model FLS-HE
Electrical connection	Connection housing: ■ Stainless steel	Connection cable ■ PVC ■ Silicone ■ PUR
Process connection	<ul style="list-style-type: none"> ■ Mounting thread upwards G 3/8" ■ Mounting flange per DIN or ANSI ■ Threaded connection per DIN 11851 ■ Clamp pipe connection per DIN 32676 ■ Ingold sanitary fitting others on request	
Guide tube diameter	17.2 mm (stainless steel 1.4435 or 1.4539, surface ground and polished)	
Guide tube length L	≤ 5,000 mm	
Float	Material: Stainless steel 1.4435 or 1.4539 Float diameter from 44 ... 120 mm Float selection depending on guide tube diameter and process conditions (see page 17, 18, 19)	
Temperature range	PVC/PUR cable -10 ... +80 °C Silicone cable -30 ... +150 °C	
Switching function	Alternatively normally open (NO), normally closed (NC) or change-over (SPDT) contact - on rising level	
Max. number of contacts	6 x NO or NC, or 4 x SPDT	6 x NO or NC, or 4 x SPDT for PVC and PUR cable 3 x NO or NC, or 2 x SPDT for silicone cable
Switch position	Dimensions L1, L2, L3 ... (from sealing face, starting from top)	
Distance between switch points	Minimum 20 mm (depending on the selection of the float and the contacts)	
Switching power	<ul style="list-style-type: none"> ■ Normally open, normally closed ■ Change-over 	
	AC ≤ 230 V; 100 VA; 1 A DC ≤ 230 V; 50 W; 0.5 A AC ≤ 230 V; 40 VA; 1 A DC ≤ 230 V; 20 W; 0.5 A	AC < 50 V; 100 VA; 1 A DC < 50 V; 50 W; 0.5 A AC < 50 V; 40 VA; 1 A DC < 50 V; 20 W; 0.5 A
Mounting position	Vertical ±30°	
Ingress protection	up to IP66 or IP68 per IEC/EN 60529 (depending on version)	

Float switch, sterile version (3-A)

Model FLS-HA3

Process connection, guide tube and float from stainless steel

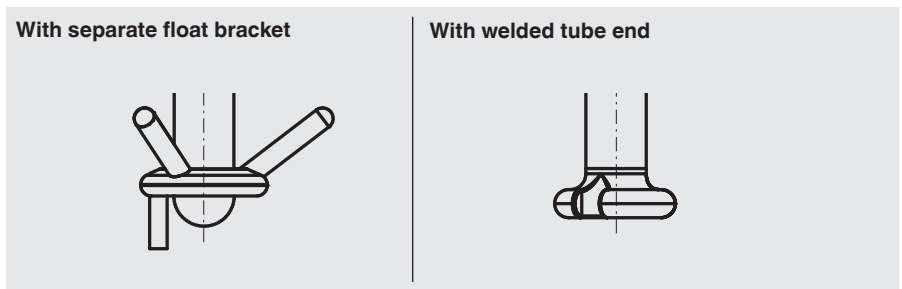
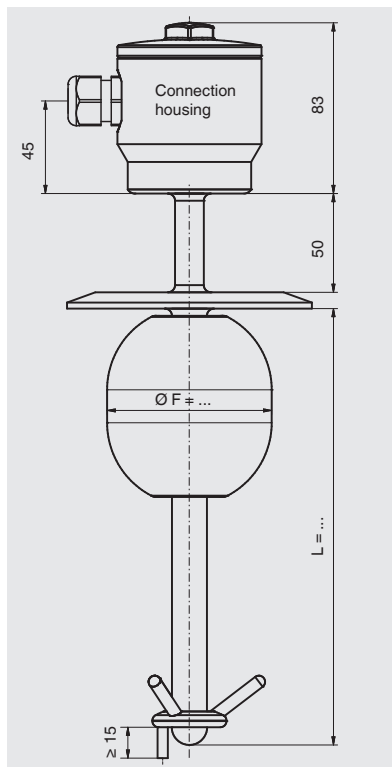

	Model FLS-HA3 with separate float bracket	Model FLS-HA3 with welded pipe connection
Electrical connection	Connection housing: stainless steel	
Process connection	<ul style="list-style-type: none"> ■ Clamp pipe connection ISO 2852, DN 32 ... DN 100 or 1.5" ... 4" ■ Clamp pipe connection DIN 32676, DN 32 ... DN 100 or 1.5" ... 4" ■ Aseptic mounting thread downwards DIN 11864-1, DN 32 ... DN 100 or 1.5" ... 4" ■ Aseptic liner DIN 11864-1, DN 32 ... DN 100 or 1.5" ... 4" ■ Aseptic flange connection DIN 11864-2 (DN 32 ... DN 50 or 1.5" ... 2" ■ Aseptic clamp connection DIN 11864-3, DN 32 ... DN 100 or 1.5" ... 4" ■ VARIVENT® (form F,N and G) ■ BioConnect® threaded connection, DN 32 ... DN 100 or 1.5" ... 2" ■ BioConnect® flange connection, DN 32 ... DN 100 or 1.5" ... 2" ■ BioConnect® clamp connection, DN 32 ... DN 100 or 1.5" ... 4" 	
Guide tube diameter	12 mm / 14 mm / 17.2 mm (stainless steel 1.4435 or 1.4539, surface ground or polished, $R_a < 0.8 \mu\text{m}$)	
Guide tube length L	$\leq 5,000$ mm	
Float	Material: Stainless steel 1.4435 or 1.4539 Float diameter: 50 ... 80 mm Float selection depending on guide tube diameter and process conditions (see page 17, 18, 19)	
Temperature range	<ul style="list-style-type: none"> ■ Process temperature -40 ... +200 °C ■ Ambient temperature -40 ... +85 °C 	
Switching function	Alternatively normally open (NO), normally closed (NC) or change-over (SPDT) contact - on rising level	
Max. number of contacts	3 x NO or NC, or 3 x SPDT	
Switch position	Dimensions L1, L2, L3 ... (from sealing face, starting from top)	
Distance between switch points	Minimum 50 mm (depending on the selection of the float and the contacts)	
Switching power	<ul style="list-style-type: none"> ■ Normally open, normally closed AC ≤ 230 V; 100 VA; 1 A DC ≤ 230 V; 50 W; 0.5 A ■ Change-over AC ≤ 230 V; 40 VA; 1 A DC ≤ 230 V; 20 W; 0.5 A 	
Mounting position	Vertical $\pm 30^\circ$	
Ingress protection	up to IP66 or IP68 per IEC/EN 60529 (depending on version)	

Options

Model	Angled version	Adjustable guide tube	ECTFE coating	Special flange from polyamide or brass	Food version
FLS-SE	x	x			x
FLS-SF	x	x			x
FLS-SA	x	x	x	x	x
FLS-SB	x	x	x	x	x
FLS-SBI (60)	x				
FLS-ME FLS-MF	x	x			
FLS-MA FLS-MB	x	x			
FLS-PF	x				
FLS-PA	x				

Angled version, material: Metal

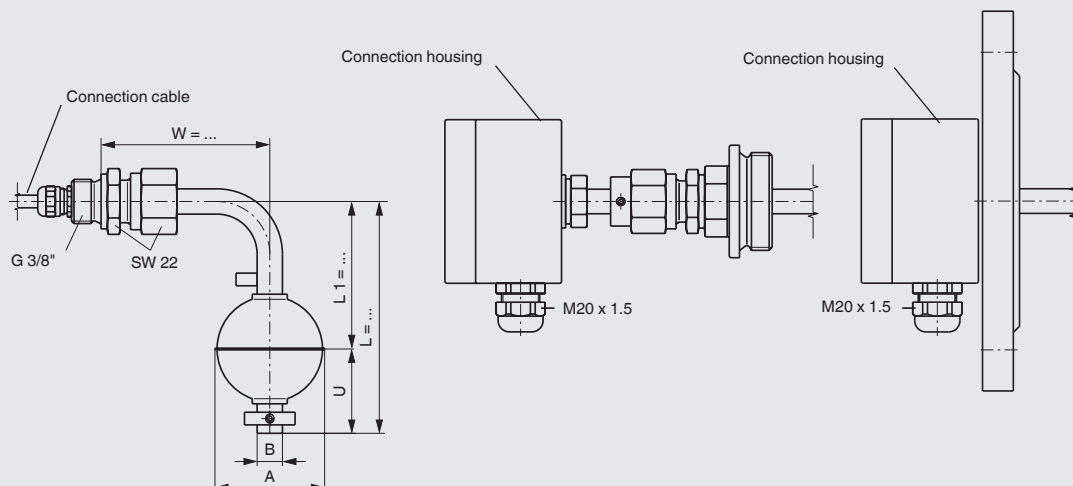

Angled version, material: Plastic

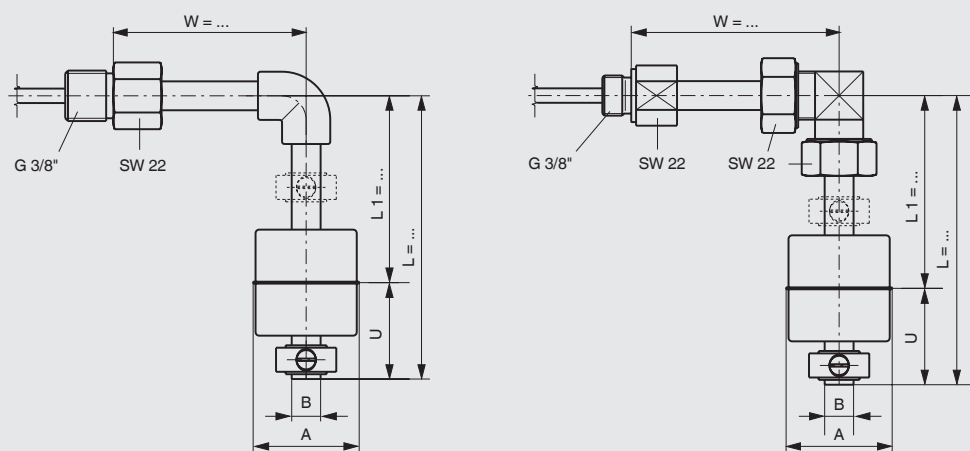

Version with adjustable guide tube

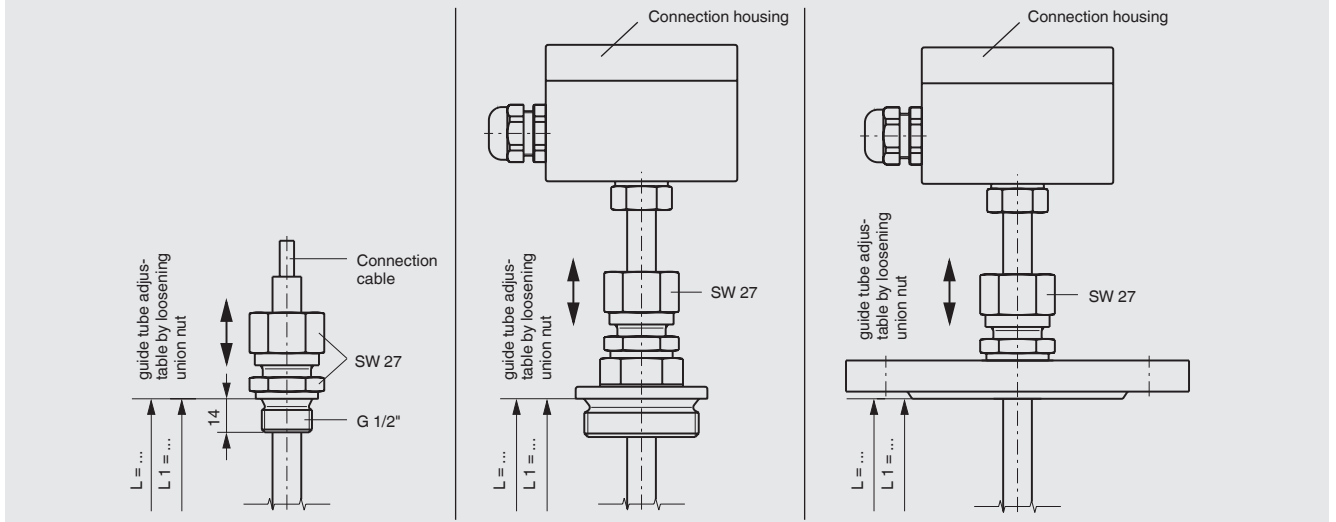

Version with ECTFE coating

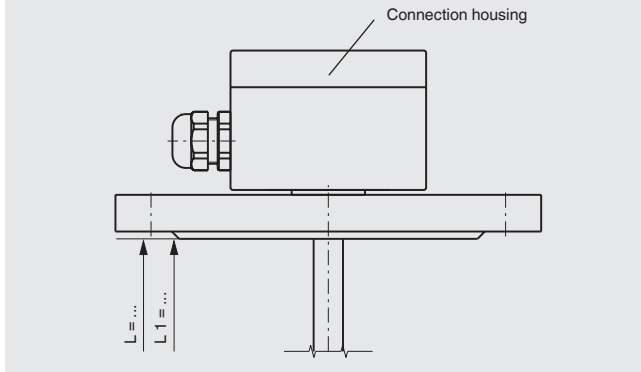

Special flange from polyamide or brass

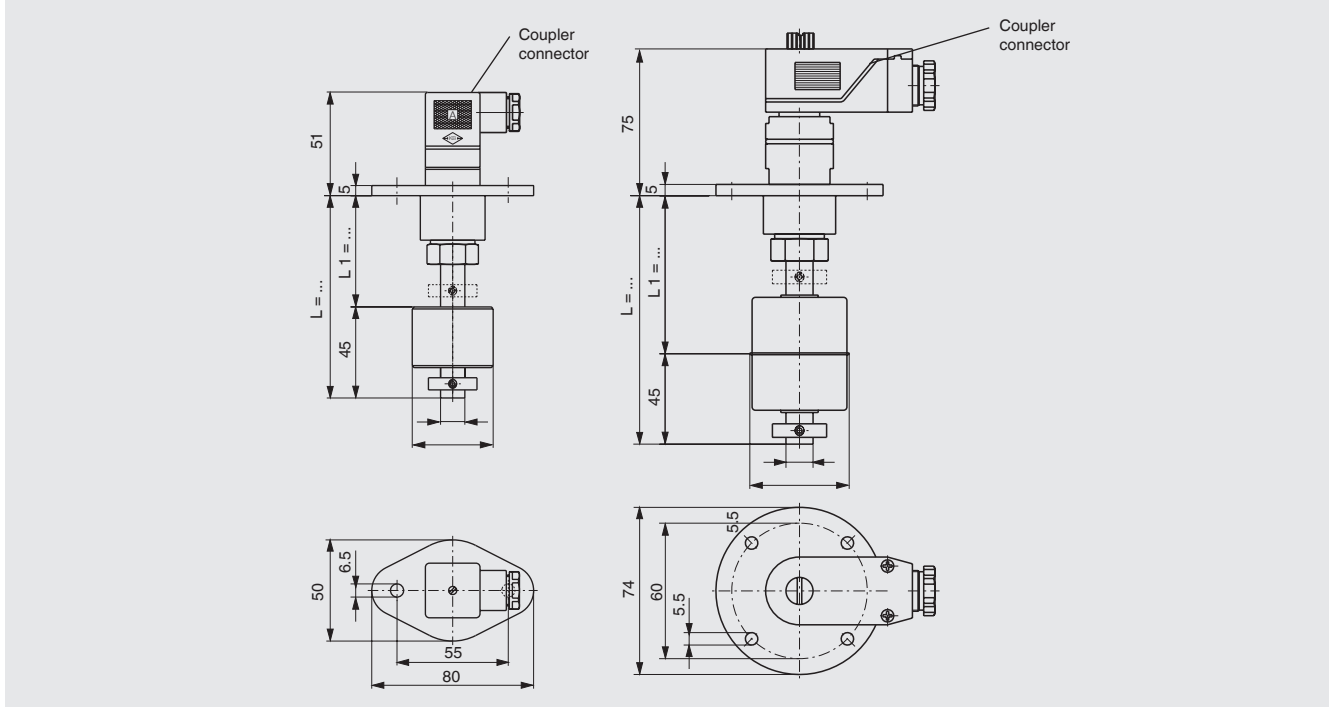

Food version for float switch

Model FLS-S

Process connection, guide tube and float from stainless steel

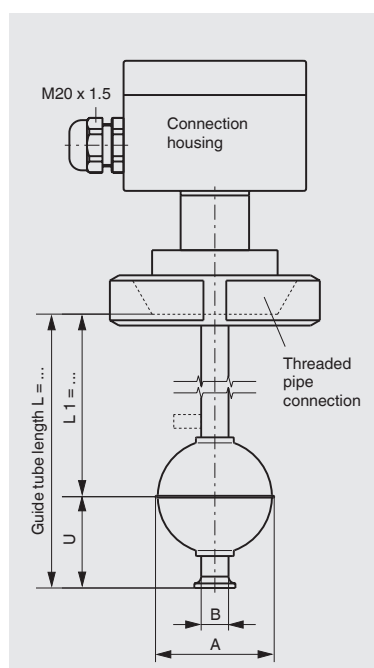

Threaded pipe connection per DIN 11851

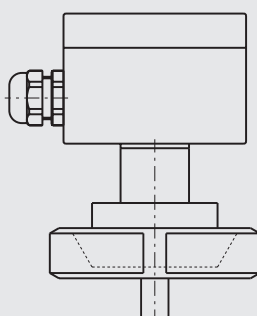

Clamp pipe connection per DIN 32676

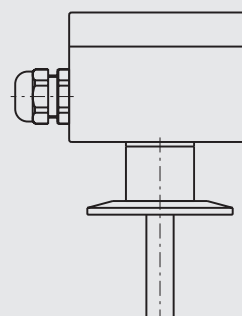

	Threaded pipe connection	Clamp pipe connection
Electrical connection	Connection housing: ■ Aluminium 64 x 58 x 34 mm, with 1 contact ■ Aluminium 80 x 75 x 57 mm, 2 or more contacts Option: Polypropylene, polyester, stainless steel	
Process connection	Threaded pipe connection per DIN 11851, downwards DN 50 ... DN 150 others on request	Clamp pipe connection per DIN 32676, DN 25 ... DN 100 or 1" ... 4" others on request
Guide tube diameter	12 mm / 14 mm / 18 mm	
Guide tube length L	Guide tube diameter 12 mm / 14 mm: ≤ 3,000 mm Guide tube diameter 18 mm: ≤ 6,000 mm	
Float	Material stainless steel 1.4435 or 1.4404, option electropolished Float diameter from 44 ... 80 mm Float selection depending on guide tube diameter and process conditions (see page 17, 18, 19)	
Temperature range ■ Process temperature	-30 ... +150 °C	
Switching function	Alternatively normally open (NO), normally closed (NC) or change-over (SPDT) contact - on rising level	
Max. number of contacts	3 x NO or NC, or 3 x SPDT	
Switch position	Dimensions L1, L2, L3 ... (from sealing face, starting from top)	
Distance between switch points	Minimum 50 mm (depending on the selection of the float and the contacts)	
Switching power ■ Normally open, normally closed ■ Change-over	AC ≤ 230 V; 100 VA; 1 A DC ≤ 230 V; 50 W; 0.5 A AC ≤ 230 V; 40 VA; 1 A DC ≤ 230 V; 20 W; 0.5 A	
Mounting position	Vertical ±30°	
Ingress protection	up to IP66 or IP68 per IEC/EN 60529 (depending on version)	

Spherical float

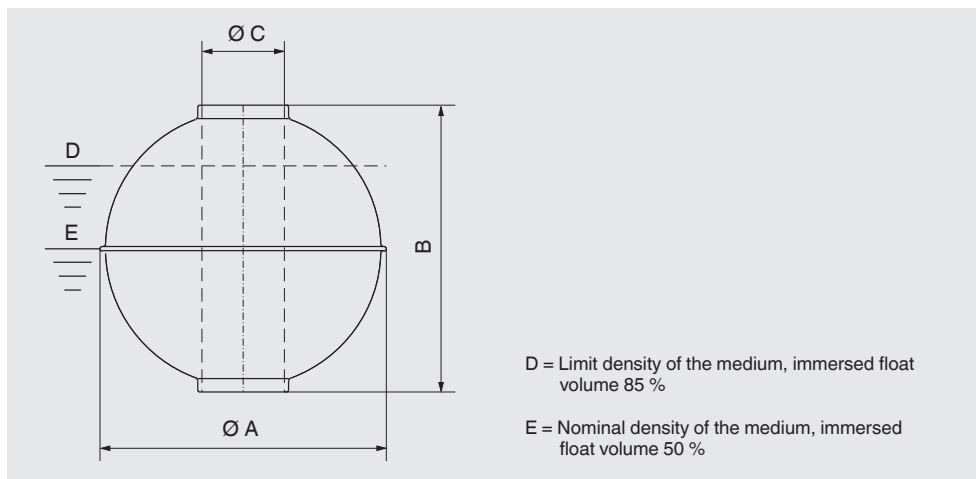

Material	Version	Suits guide tube Ø in mm	Ø A in mm	B in mm	Ø C in mm	Max. operating pressure in bar	Max. operating temp. in °C	Limit density 85 % in kg/m ³	Order no.
Stainless steel 1.4571	V29A/0.2	8	29	28	9	25	100	920	27355
	V52A	12	52	52	15	40	300	700	5462
	V62A	12	62	61	15	32	300	670	5511
	V83A	12	83	81	15	25	300	430	5485
	V80A	18	80	76	23	25	300	680	5478
	V98A	18	98	96	23	25	300	640	5489
	V105A	18	105	103	23	25	300	530	20652
	V120A	18	120	117	23	25	300	390	21721
Titanium 3.7035	T29A	8	29	28	9	30	100	700	5522
	T52A	12	52	52	15	25	300	720	5526
	T52A/1	12	52	52	15	80	300	1060	-
	T62A	12	62	62	15	25	300	520	5536
	T83A	12	83	81	15	25	300	350	5544
	T80A	18	80	76	23	25	300	665	112263
	T98A	18	98	96	23	25	300	495	-
	T105A	18	105	103	23	25	300	370	-
	T120A	18	120	117	23	25	300	330	-
Stainless steel 1.4571 ECTFE coated	VEC53A	12	53	53	14	25	Depending on medium	745	-
	VEC63A	12	63	62	14	25	Depending on medium	590	-
	VEC84A	12	84	82	14	25	Depending on medium	400	-
	VEC81A	18	81	77	22	25	Depending on medium	720	-
	VEC99A	18	99	97	22	25	Depending on medium	675	-
	VEC106A	18	106	104	22	25	Depending on medium	630	-
	VEC121A	18	121	118	22	25	Depending on medium	460	-

Note: The optimum float will be selected after a feasibility test carried out by KSR.

Cylindrical float

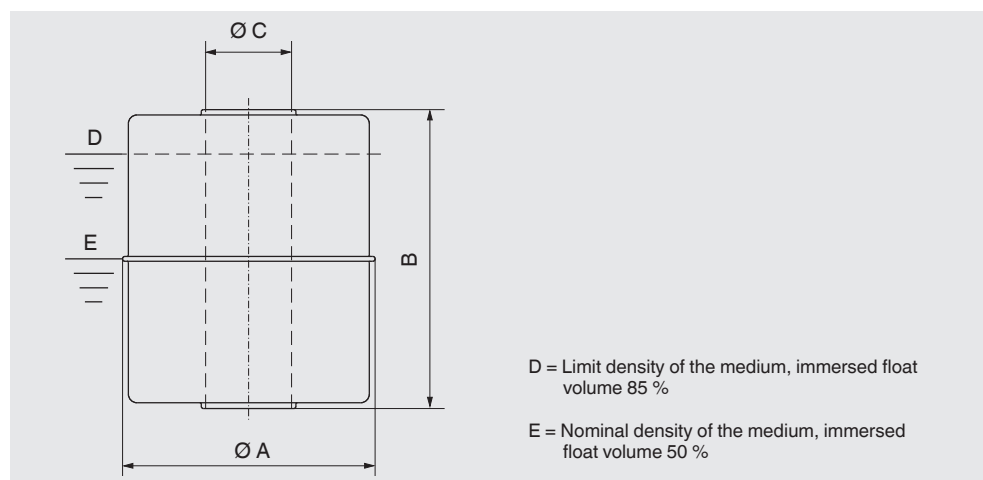

Material	Version	Suits guide tube Ø in mm	Ø A in mm	B in mm	Ø C in mm	Max. operating pressure in bar	Max. operating temp. in °C	Limit density 85 % in kg/m ³	Order no.
Stainless steel 1.4571	V27A	8	27	31	10	16	100	700	9679
	V44A	12	44	52	15	16	300	720	9681
Titanium 3.7035	T44A	12	44	52	15	16	300	720	9744
Buna (NBR)	B20A	8	20	20	9	3	80	940	9719
	B23A	8	23	25	9	3	80	800	9721
	B25A	8	25	14	9	3	80	790	9720
	B30A	8	30	45	13	3	80	680	34047
	B40A	12	40	30	15	3	80	580	9728
	B40A/120	12	40	120	15	3	80	410	-
	B50A	18	50	45	19	3	80	500	9725
PVC	P44A	12	44	44	14	3	60	650	33790
	P55A	16	55	54	22	3	60	800	-
	P55A/26	20	55	80	26	3	60	920	-
	P55A/70	16	55	70	22	3	60	670	-
	P80A	20	80	79	25	3	60	570	33796
Polypropylene	PP27A	8	27	29	9	3	80	755	15516
	PP35A	8	35	33	9	3	80	675	100347
	PP44A	12	44	44	14	3	80	480	15514
	PP55A	16	55	54	22	3	80	580	33792
	PP55A/26	20	55	80	26	3	80	670	-
	PP80A	20	80	79	25	3	80	430	33795
PVDF	PF44A	12	44	55	14	3	100	780	33791
	PF55A	16	55	69	22	3	100	820	116235
	PF55A/26	20	55	80	26	3	100	1,140	-
	PF80A	20	80	79	25	3	100	680	33797
Stainless steel 1.4571 E-CTFE coated	VEC45A	12	45	53	14	16	Depending on medium	780	-

Note: The optimum float will be selected after a feasibility test carried out by KSR.

Hygienic float

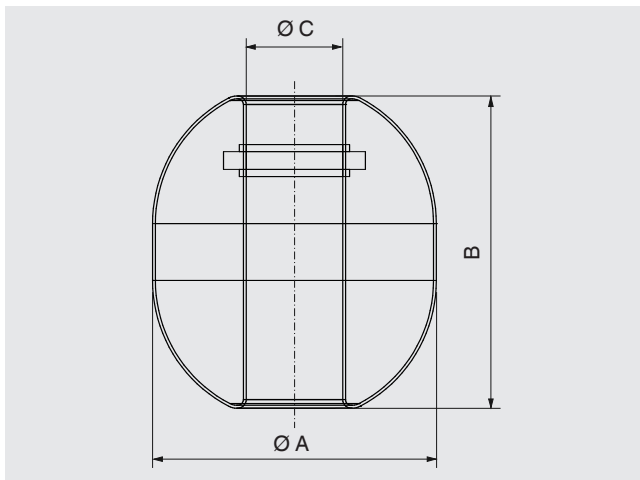

Material	Model	Version	Suits guide tube Ø in mm	Ø A in mm	B in mm	Ø C in mm	Max. operating pressure in bar	Max. operating temp. in °C	Limit density 85 % in kg/m ³	Order no.
Stainless steel 1.4435	V80/88/A34/3A/35, axial	V80A	18	80	55	23	16	250	800	025755
	V50/55/17/A34/3A/35	V50A	12	50	55	16.8	16	250	1,100	026400
	V55/70/A34/3A/35 axial	V55A	12	55	70	17	16	250	900	124069

Note: The optimum float will be selected after a feasibility test carried out by KSR.

Contact protection measures

The reed contacts should be protected against any voltage or current spikes that might occur.

Depending on the different load types different protective circuits are used.



Model KFD2-ER-1.6



RC element

Contact protection relays	Contacts	Input	Power supply	Approval number	Order no.
KFD2-ER-1.6	1 x change-over AC 250 V, 2 A	2 x contacts	DC 20 ... 30 V	-	112941
KFD2-SR2-Ex2.W	2 x change-over AC 253 V, 2 A	2 x contacts	DC 20 ... 30 V	II 1 GD EEx ia IIC PTB 02 ATEX 2073	112944
KFA6-ER-1.6	1 x change-over AC 250 V, 2 A	2 x contacts	AC 230 V	-	112942
KFA6-SR2-Ex2.W	2 x change-over AC 253 V, 2 A	2 x contacts	AC 230 V	II 1 GD EEx ia IIC PTB 02 ATEX 2073	112943

RC element	Capacitance	Resistance	Voltage	Order no.
B3/115	0.33 μ F	470 Ohm	AC 115 V	110446
B3/230	0.33 μ F	1,000 Ohm	AC 230 V	110460

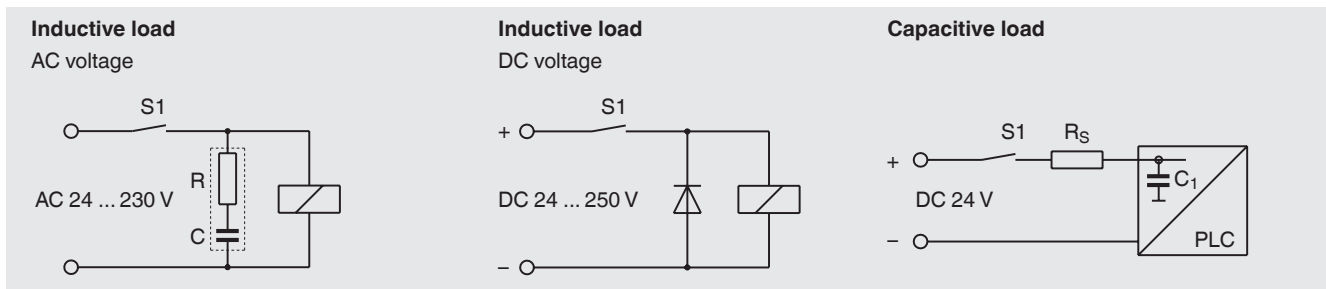

Ordering information

To order the described product the order number (if available) is sufficient.

Alternatively:

Model / Version / Electrical connection / Process connection / Guide tube diameter / Guide tube length L / Information about contact (switching function, number of switch points, switch position) / Process specifications (operating temperature and pressure, limit density) / Options

© 01/2010 KSR KUEBLER Niveau-Messtechnik AG, all rights reserved.
The specifications given in this document represent the state of engineering at the time of publishing.
We reserve the right to make modifications to the specifications and materials.