



## UNICO®

Single jet volume measuring meter  
for warm water up to 90 °C  
for hot water up to 120 °C  
DN 15, 20

### Your benefits

- Robust, high grade wear resistant materials:  
Excellent measuring stability and reliability
- Measurement of lowest flow rates:  
Increased cost effectiveness

### Application

- Volume measuring meter as component to heat measurement or for solar installations
- For flow rates up to 2,5m<sup>3</sup>/h

### Features

- Single jet dry-dial meter with magnetic coupling
- Register can be turned for best readout position
- Maximum operating pressure PN 16 bar
- Maximum operating temperature 90 °C or 120 °C
- Horizontal or vertical installation
- Reed pulser IPG14 with 1,5 m cable (Standard pulse value 2,5 litres)
- High grade wear resistant and corrosion proof materials
- Inlet strainer
- Magnetic protective cover against external influences
- **CE** Conformity according to European Measuring Instruments Directive (MID)
- Environmental class B, Accuracy class 3

### Options

- Drilling for temperature sensor directly mounted to meter according to EN 1434 for 130 mm execution
- 1" NPSM connection thread on meter for 130 mm execution (not in combination with temperature sensor drilling)
- PTB Approval according to EN 1434
- Other measuring ranges
- Reed pulser IPG14 with 3 m cable
- Different pulse values  
☐ Documentation: IPG14 - EPe40217

## Technical Data

Nominal diameter	DN	mm	15	20	20	20
Operating pressure	PN	bar	16	16	16	16
Connection thread on meter	G...B	Inch	¾	1	1	1
Connection thread on coupling	R...	Inch	½	¾	¾	¾
Nominal flow rate	q <sub>p</sub>	m <sup>3</sup> /h	1,5	1,5	1,5	2,5
Maximum flow rate	q <sub>s</sub>	m <sup>3</sup> /h	3	3	3	5
Minimum flow rate horizontal ±5%	q <sub>i</sub>	l/h	30	30	30	50
Minimum flow rate vertical ±5%	q <sub>i</sub>	l/h	60	60	60	100
Kvs-value		m <sup>3</sup> /h	3	3	3	5
Operating temperature range		°C	2... 90/120	2... 90/120	2... 90/120	2... 90/120
Standard measuring range horizontal	q <sub>i</sub> /q <sub>p</sub>		1:50	1:50	1:50	1:50
Standard measuring range vertical	q <sub>i</sub> /q <sub>p</sub>		1:25	1:25	1:25	1:25

Dimensions and weights						
Length without couplings	A	mm	110	110	130	130
Length with couplings		mm	184	202	222	222
Width	B	mm	72	72	72	72
Height with pulser and magnetic protection cover	C	mm	108	108	108	108
Height from pipe centre	D	mm	90	90	90	90
Weight without couplings		app. g	760	810	840	790

## Dimension Diagram

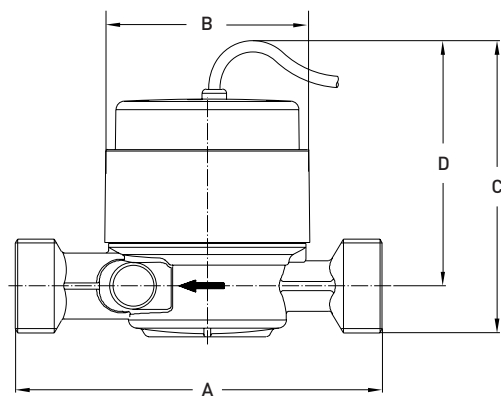

## Typical Head Loss Curve

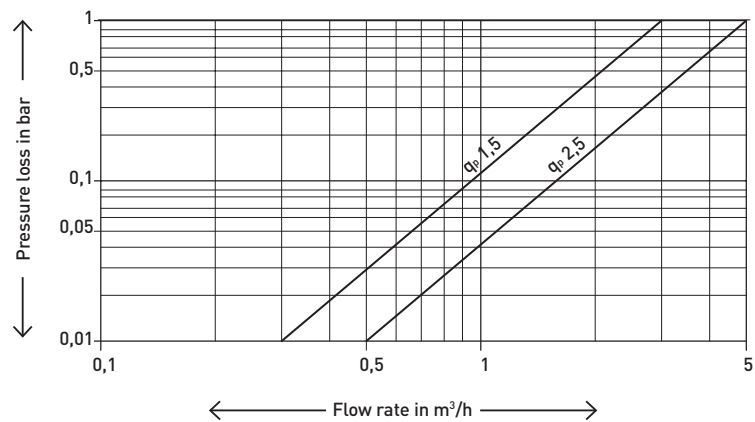

## Installation

Pipeline:	horizontal	—
	vertical	
Meter head:	upwards	↑
	sideways	←→

## Pulse Value Table

Pulse value	q <sub>p</sub>	1,5	—	0,25	1	2,5	10	25
(1 Pulse = ...Liter)	q <sub>p</sub>	2,5	1	2,5	10	25	100	250